

Miele

Operating and installation instructions



Frost free fridge freezer KDN 37132 iD

To avoid the risk of accidents or damage to the appliance it is **essential** to read these instructions before it is installed and used for the first time.

en - GB

M.-Nr. 09 485 700

Contents

Guide to the appliance	4
Optional accessories	6
Bottle rack	6
Split shelf	6
Caring for the environment	7
Warning and Safety instructions	8
How to save energy	17
Switching on and off	19
Before using for the first time	19
Switching off for longer periods of time	20
The correct temperature	21
... in the refrigerator	21
... in the freezer	21
Temperature display	22
Setting the temperature	22
Selecting settings	23
Settings mode	23
Activating or deactivating the lock	23
Using Super freeze	25
Super freeze	25
Temperature and door alarm	26
Door alarm	26
Switching the alarm off early	26
Storing food in the refrigerator section	27
Different storage zones	27
Food which is not suitable for storing in the refrigerator	28
When shopping for food	28
Storing food correctly	29
Fruit and vegetables	29
Protein rich food	29
Adjusting the interior fittings	30
Adjusting the door shelf/bottle shelf	30
Moving the bottle holder	30
Moving the shelves	30

Freezing and storing food	31
Maximum freezing capacity	31
Freezing fresh food	31
Storing frozen food	31
Home freezing	32
Hints on home freezing	32
Packaging	32
Before placing food in the freezer section	33
Placing food in the freezer section	33
Defrosting	34
Ice cubes	34
Cooling drinks	34
Defrosting	35
Refrigerator section	35
Cleaning and care	36
Cleaning the interior and accessories	37
Ventilation gaps	37
Door seals	38
Problem solving guide	39
Noises	45
After Sales / Guarantee	46
Guarantee	46
Note for test institutes	47
Electrical connection	48
Installation	49
Location	49
Climate range	49
Ventilation	50
Before installing the appliance	51
Building-in dimensions	52
Changing the door hinging	53
Building in the appliance	57
Securing the appliance in the niche	62
Securing the furniture door to the appliance door	64

Guide to the appliance

Control panel

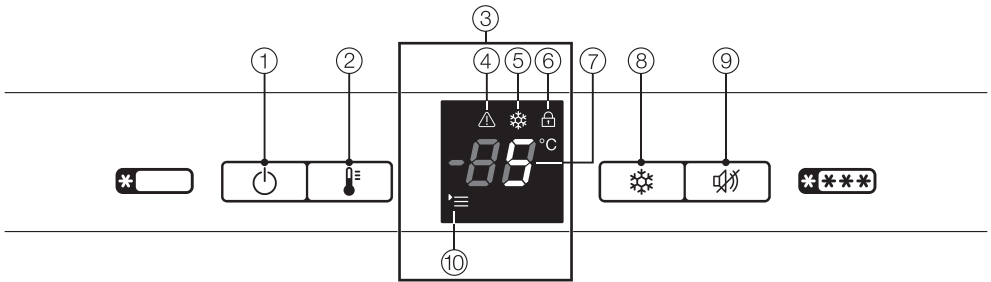

① On/Off button

② Temperature selector button

③ Display

④ Alarm symbol

⑤ Super freeze symbol

⑥ Lock symbol

⑦ Temperature display

⑧ Super freeze button

⑨ Alarm off button

⑩ Menu symbol

(Settings mode:

For activating and deactivating the lock)

Guide to the appliance

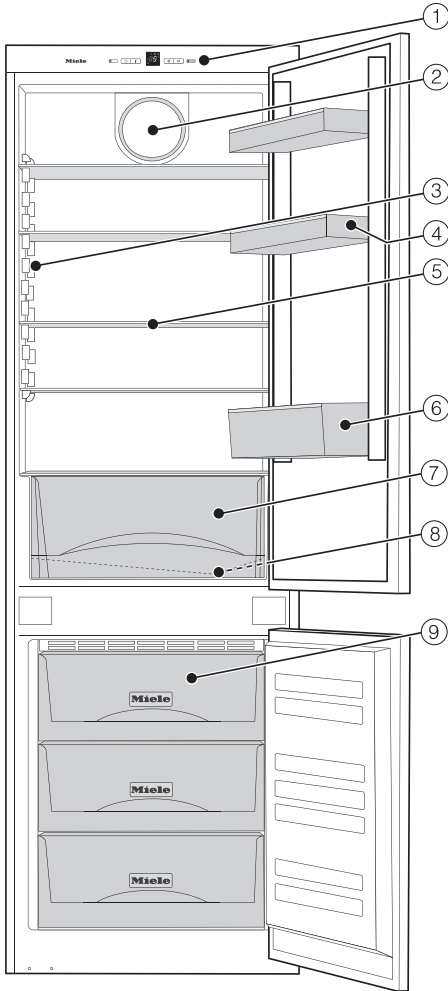

① Control panel

② Fan

③ Interior lighting

④ Door shelf / Egg tray

⑤ Adjustable shelf

⑥ Bottle shelf

⑦ Fruit and vegetable drawer

⑧ Condensate channel and
drain hole

⑨ Freezer drawers

Guide to the appliance

Optional accessories

Bottle rack

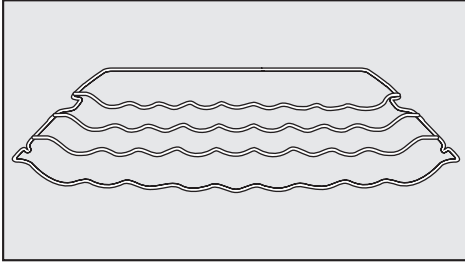

Bottles can be stored horizontally using the bottle rack to save space. The bottle rack can be placed at different positions in the appliance.

Split shelf

In order to accommodate tall items in the appliance, one of the shelves is divided. The front section can be carefully pushed under the rear section.

Microfibre cloth

The microfibre cloth helps remove fingerprints and light soiling from surfaces such as stainless steel, glass, plastic and chrome without the use of chemicals.

Optional accessories are available from Miele or via the internet.



www.miele-shop.com

Disposal of the packing material

The packaging is designed to protect the appliance from damage during transportation. The packaging materials used are selected from materials which are environmentally friendly for disposal and should be recycled.

Recycling the packaging reduces the use of raw materials in the manufacturing process and also reduces the amount of waste in landfill sites.

Disposal of your old appliance

Electrical and electronic appliances often contain valuable materials. They also contain materials which, if handled or disposed of incorrectly, could be potentially hazardous to human health and to the environment. They are, however, essential for the correct functioning of your appliance. Please do not therefore dispose of it with your household waste.

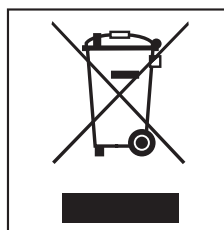

Please dispose of it at your local community waste collection / recycling centre or contact your dealer for advice. Ensure that it presents no danger to children while being stored for disposal.

Take care not to damage the pipework at the back of it before or during transportation to an authorised collection depot.

In this way, refrigerant in the pipework and oil in the compressor will be contained, and will not leak out into the environment.

Warning and Safety instructions

This appliance complies with all statutory safety requirements. Inappropriate use can, however, lead to personal injury and damage to property.

To avoid the risk of accidents and damage to the appliance, please read these instructions carefully before installation and before using it for the first time. They contain important information on installation, safety, use and maintenance.

Miele cannot be held liable for damage caused by non-compliance with these Warning and Safety instructions.

Keep these instructions in a safe place and ensure that new users are familiar with the content. Pass them on to any future owner.

Correct application

► The appliance is not designed for commercial use. It is intended for use in domestic households and similar working and residential environments.

This appliance is not intended for outdoor use.

► This appliance is intended for domestic use only for cooling and storing food and drink as well as for storing deep frozen food, freezing fresh food and for making ice.

Any other usage is not supported by the manufacturer and could be dangerous.

Warning and Safety instructions

▶ The appliance is not suitable for storing and keeping cool medicines, blood plasma, laboratory preparations or other such materials or products. Incorrect use of the appliance for such purposes can cause deterioration of the items stored. The appliance is not suitable for use in areas where there is a risk of explosion. Miele cannot be held liable for damage resulting from incorrect or improper use or operation.

▶ The appliance can only be used by people with reduced physical, sensory or mental capabilities, or lack of experience and knowledge, if they are supervised whilst using it, or have been shown how to use it in a safe way and recognise and understand the consequences or incorrect operation.

Safety with children

▶ Children under 8 years of age must be kept away from the appliance unless they are constantly supervised.

▶ Children 8 years and older may only use the appliance unsupervised if they have been shown how to use it in a safe way and recognise and understand the consequences of incorrect operation.

▶ Children must not be allowed to clean or maintain the appliance unsupervised.

▶ Please supervise children in the vicinity of the appliance and do not let them play with it.

Warning and Safety instructions

▶ Danger of suffocation. Packaging, e.g. plastic wrappings, must be kept out of the reach of babies and children. Whilst playing, children could become entangled in packaging or pull it over their head and suffocate.

Technical safety

▶ The coolant system is tested for leaks. The appliance complies with statutory safety requirements and the appropriate EU guidelines.

▶ This appliance contains the coolant Isobutane (R600a), a natural gas which is environmentally friendly. Although it is flammable, it does not damage the ozone layer and does not increase the greenhouse effect.

The use of this coolant has, however, led to a slight increase in the noise level of the appliance. In addition to the noise of the compressor, you might be able to hear the coolant flowing around the system. This is unavoidable, and does not have any adverse effect on the performance of the appliance.

Care must be taken during the transportation and installation of the appliance that no parts of the cooling system are damaged. Leaking refrigerant can damage the eyes.

In the event of any damage:

- avoid any flames or anything which creates a spark,
- disconnect the appliance from the electricity supply,
- ventilate the room where the appliance is located for several minutes, and
- call the Service department.

Warning and Safety instructions

▶ The more coolant there is in an appliance, the larger the room it should be installed in. In the event of a leakage, if the appliance is in a small room, there is the danger of combustible gases building up. For every 8 g of coolant at least 1 m³ of room space is required. The amount of coolant in the appliance is stated on the data plate inside the appliance.

▶ To avoid the risk of damage to the appliance, make sure that the connection data (fuse rating, frequency and voltage) on the data plate corresponds to the household supply. Check that this is the case before connecting the appliance. Consult a qualified electrician if in any doubt.

▶ The electrical safety of this appliance can only be guaranteed when it is correctly earthed. It is essential that this standard safety requirement is met. If in any doubt, please have the electrical installation tested by a qualified electrician.

▶ If the electrical connection cable is faulty it must only be replaced by a Miele approved service technician to protect the user from danger.

▶ Do not connect the appliance to the mains electrical supply by a multi-socket adapter or extension lead. These are a fire hazard and do not guarantee the required safety of the appliance.

▶ Do not use in a damp environment (e.g. garage or utility room). Moisture could reach live components or the electrical connection and cause a short circuit.

Warning and Safety instructions

- ▶ This appliance must not be used in a non-stationary location (e.g. on a ship).
- ▶ A damaged appliance can be dangerous. Check the appliance for visible signs of damage. Do not use a damaged appliance.
- ▶ For safety reasons, this appliance may only be used when it has been built in.
- ▶ The appliance must be disconnected from the mains electricity supply during installation, maintenance and repair work. Ensure that power is not supplied to the appliance until after it has been installed or until after any maintenance or repair work has been carried out.
- ▶ Installation, maintenance and repairs may only be carried out by a Miele authorised service technician. Installation, maintenance and repairs by unqualified persons could be dangerous.
- ▶ While the appliance is under guarantee, repairs should only be undertaken by a Miele authorised service technician. Otherwise the guarantee is invalidated.
- ▶ Miele can only guarantee the safety of the appliance when original Miele replacement parts are used. Faulty components must only be replaced by genuine Miele original spare parts.

Correct use

- ▶ The appliance is designed for use within certain climate ranges (ambient temperatures), and should not be used outside this range. The climate range of the appliance is stated on the data plate inside the appliance. Installing it in a room with too low an ambient temperature will lead to the appliance switching off for longer periods so that it cannot maintain the required temperature.
- ▶ Do not cover or block the air vents as this could impair the efficiency of the appliance, increase the electricity consumption and could cause damage to the appliance.
- ▶ If storing food which contains a lot of fat or oil in the appliance or the door, make sure that it does not come into contact with plastic components as this could cause stress cracks or break the plastic.
- ▶ Do not store explosive materials in the appliance or any products containing propellants (e.g. spray cans). Electrical components could cause flammable vapours to ignite. Danger of fire and explosion.
- ▶ Do not operate any electrical equipment (e.g. an electric ice-cream maker) inside the appliance. Danger of sparking and explosion.
- ▶ Do not store cans or bottles containing carbonated drinks or liquids which could freeze in the freezer section. The cans or bottles could explode. Danger of injury and damage to the appliance.

Warning and Safety instructions

- ▶ If storing alcohol with a high percentage proof, make sure it is tightly closed and stored upright. Danger of explosion.
- ▶ When cooling drinks quickly in the freezer section, make sure bottles are not left in for more than one hour, otherwise they could burst, causing injury or damage.
- ▶ Never handle frozen food or the metal parts of the appliance with wet hands. Your hands may freeze to the frozen food or metal parts. Danger of frost burn.
- ▶ Do not take ice cubes out with your bare hands and never place ice cubes or ice lollies in your mouth straight from the freezer. The very low temperature of the frozen ice or lollies can cause frost burn to the lips and tongue.
- ▶ Do not refreeze partially or fully defrosted food. Consume defrosted food as soon as possible, as it will lose its nutritional value and spoil if left for too long. Defrosted food may only be re-frozen after it has been cooked.
- ▶ Observe the manufacturer's "use-by" dates and storage instructions given on food to avoid the risk of food poisoning. Storage times will depend on several factors, including the freshness and quality of the food as well as the temperature at which it is stored.
- ▶ Only use genuine original Miele accessories with this appliance. Using spare parts or accessories from other manufacturers will invalidate the guarantee, and Miele cannot accept liability.

Cleaning and care

- ▶ Do not use any oils or grease on the door seals, as these will cause the seals to deteriorate and become porous with time.
- ▶ Do not use a steam cleaning appliance to clean this appliance. Steam could reach electrical components and cause a short circuit.
- ▶ Do not use sharp edged objects to
 - remove frost and ice,
 - lift food.

They will damage the evaporator, causing irreversible damage to the appliance.

- ▶ Never place electric heaters or candles in the appliance to defrost it. These can damage the plastic parts.
- ▶ Do not use defrosting sprays or de-icers, as they could contain substances which could damage the plastic parts and which may cause the build up of gases and pose a danger to health.

Warning and Safety instructions

Disposal of your old appliance

▶ Before disposing of an old appliance, first make the door latch or lock unusable.

This way you will prevent children from accidentally locking themselves in and endangering their lives.

▶ Be careful not to damage any part of the pipework whilst awaiting disposal, e.g. by

- puncturing the refrigerant channels in the evaporator,
- bending any pipework,
- scratching the surface coating.

Splashes of refrigerant can damage the eyes.

How to save energy

	Normal energy consumption	Increased energy consumption
Installation site / Maintenance	In a ventilated room.	In an enclosed, unventilated room.
	Protected from direct sunlight.	In direct sunlight.
	Not near to a heat source (radiator, oven).	Near to a heat source (radiator, oven).
	Where the ideal ambient room temperature is approx. 20°C.	Where there is a high ambient room temperature.
	Ventilation gaps uncovered and dusted regularly.	Ventilation gaps covered up or dusty.
	Compressor and metal grille (heat exchanger) dusted at least once a year.	Dust build-up on the compressor and metal grille (heat exchanger).
Temperature setting	Refrigerator section 4 to 5°C	With a low temperature setting: the colder the temperature in the refrigerator section, the higher the energy consumption.
	Freezer section -18 °C	

How to save energy

	Normal energy consumption	Increased energy consumption
Use	Drawers, shelves and racks arranged as they were when the appliance was delivered.	
	Only open the door when necessary and for as short a time as possible. Store food in an organised way.	Frequent opening of the door for long periods will cause a loss of coldness. The appliance works harder to cool down and the compressor runs for longer periods.
	Take an insulated cool bag with you when shopping and place food in the appliance as soon as possible. Replace any food removed as quickly as possible, before it begins to thaw. Allow hot food and drinks to cool down before placing them in the appliance.	Hot food or food at room temperature raises the temperature inside the appliance. The appliance works harder to cool down and the compressor runs for longer periods.
	Store food covered or packaged.	The evaporation or condensation of liquids will cause a loss of coldness in the refrigerator.
	Place frozen food in the refrigerator to defrost.	
	Do not over-fill the appliance to allow air to circulate.	

Before using for the first time

Protective foil

The stainless steel trim to the interior shelves and the door shelves has a layer of protective foil to prevent damage during transportation.

- Carefully remove the protective foil from the stainless steel trim.

Cleaning

- Clean the inside of the appliance and the accessories. See "Cleaning and care" for more information.

Accessories

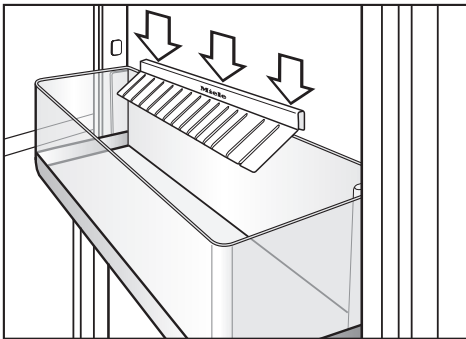

- Attach the bottle holder centrally along the rear edge of the bottle shelf, as shown.

The flexible ribs grip the bottles securely when the door is opened and closed.

Switching on



- Press the On/Off button.

The appliance will start to cool and the temperature required will appear in the temperature display. The interior lighting will come on when the door is opened.

To enable the temperature to get sufficiently cold inside the appliance, allow the appliance to run for a few hours before placing food in it.

Switching off



- Press the On/Off button until the display goes out.

The cooling system switches off. If this does not happen, the safety lock is still activated (see "Selecting settings - To deactivate the lock").

Switching on and off

Switching off for longer periods of time

If the appliance is not going to be used for a longer period of time, e.g. whilst on holiday:

- switch the appliance off,
- disconnect it from the mains,
- clean the appliance out and
- leave the doors ajar to air it.

If, during a long absence, the appliance is switched off but not cleaned out and the doors are left shut, there is a danger of mould and odours building up inside the appliance.

The correct temperature

It is very important to set the correct temperature for storing food in the appliance. Micro-organisms will cause food which is not stored at the correct temperature to deteriorate rapidly. Temperature influences the growth rate of these micro-organisms. Reducing the temperature reduces their growth rate.

The temperature in the appliance will rise:

- the more often the door is opened and the longer it is kept open,
- the more food that is placed in it,
- the warmer the food is which is being put into it,
- the higher the ambient temperature surrounding the appliance.

The appliance is designed for use in specific ambient temperatures (climate ranges). Do not use in ambient temperatures for which it is not designed.

. . . in the refrigerator

We recommend a temperature of **4°C** in the middle of the refrigerator.

. . . in the freezer

To freeze fresh food and to store frozen food for a long time, a temperature of **-18°C** is required. At this temperature the growth of micro-organisms is generally halted. As soon as the temperature rises above -10°C, the micro-organisms become active in the food again so that it cannot be kept as long. For this reason, partially defrosted or defrosted food must not be re-frozen. Food may be re-frozen once it has been cooked, as the high temperatures achieved when cooking destroy most micro-organisms.

The correct temperature

Temperature display

The temperature display on the control panel always shows the **required** temperature.

For example, if you want to set the temperature for the refrigerator section at **4 °C**,

- Press the temperature selector button repeatedly until the lights up in the temperature display.

The average temperature in the freezer section will then be approx. **-18 °C**.

However, if frozen food is to be stored in the **freezer section** then a setting of between **3 °C to 5 °C** is recommended to ensure that the required temperature in the freezer section is maintained.

It is also advisable to set the temperature within this range if the doors are opened frequently, large quantities of food are being stored in the appliance or there is a high ambient temperature.

Setting the temperature

The higher or lower the temperature in the refrigerator, the higher or lower it is in the freezer section.



- Press the temperature selector button repeatedly until the temperature you want appears in the temperature display.

The first time you press the button the last temperature selected will flash in the display.

The temperature value will change up until the setting for 9°C is reached. It will then drop back to the 1°C setting.

The newly selected temperature will be adopted automatically after a short while.

The temperature in the appliance will adjust slowly until it is at this value.

Settings mode

The lock is activated or deactivated in Settings mode.

Activating or deactivating the lock

⌘

Settings mode is represented in the display by the Menu symbol *≡.

See below for instructions on how to **activate or deactivate the lock**.

Activating or deactivating the lock

The lock can be activated to prevent the appliance being switched off by mistake.

– To activate the lock



- Press the Super freeze button for approx. five seconds.

The Menu symbol *≡ will light up and ⌘ will start flashing in the display. Settings mode is now activated.



- Press the Super freeze button briefly to call up the lock function. ⌘ will appear in the display.



- Press the Super freeze button briefly to activate the lock.

The Lock symbol  will light up.

To come out of Settings mode:

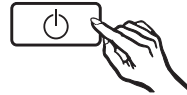

- Press the On/Off button.



The temperature will appear in the display.

Selecting settings

– To deactivate the lock



- Press the Super freeze button for approx. five seconds.

The Lock symbol  and the Menu symbol  will light up and  will flash in the display.
Settings mode is now activated.



- Press the Super freeze button briefly to call up the lock function.

 will appear in the display.



- Press the Super freeze button briefly to deactivate the lock.

The Lock symbol  will go out.

To come out of Settings mode:



- Press the On/Off button.

The temperature will appear in the display.

Super freeze

For optimum results switch on the Super freeze function before putting fresh food into the freezer section.

This helps food to freeze quickly and retain its nutrients, vitamins, flavours and appearance.

Super freeze is not necessary:

- when placing food in the freezer section that is already frozen.
- when freezing up to 1 kg fresh food daily.

Switching on Super freeze

When freezing small quantities of food in the freezer, the Super freeze function should be switched on **6 hours beforehand**. When freezing **the maximum load of food** the Super freeze function should be switched on **24 hours beforehand**.



- Press the Super freeze button.

The Super freeze symbol ❄ will light up. The appliance will work at full power to lower the temperature in the appliance.

Switching off Super freeze

The Super freeze function will switch off automatically after approx. 65 hours. The Super freeze symbol ❄ will go out and the appliance will run at normal power again.

You can switch the Super freeze function off earlier to save energy:



- Press the Super freeze button. The Super freeze symbol ❄ will go out.

The appliance will run at normal power again.

Temperature and door alarm

This appliance has a warning system which ensures that the temperature in the freezer section cannot rise unnoticed and to avoid energy being wasted if a door is left open.

Temperature alarm

An alarm will sound if the temperature in the **freezer section** becomes too warm. The temperature display and the alarm symbol  will also flash.

The temperature the appliance is set at determines the temperature the appliance recognises as being too warm.

For example, the alarm may sound and the temperature display and the Alarm symbol  may flash,

- when freezing large amounts of food at once,
- when freezing fresh food which is still warm,
- if a lot of room air enters the freezer section when food is being loaded, re-arranged or taken out,
- in the event of a power cut,
- if the appliance has a fault.

The alarm will stop and the Alarm symbol  will go out when the temperature reaches the correct level again.

However, if the temperature in the freezer section remains above $-18\text{ }^{\circ}\text{C}$ for a long time, check that the frozen food has not started to defrost. If it has, check that it is still safe to use, and if so, use it as quickly as possible. Defrosted food may only be re-frozen after it has been cooked.

Door alarm

The alarm will sound if a door is left open for more than 60 seconds.

The alarm will stop as soon as the door is closed.

Switching the alarm off early

If the noise disturbs you, you can switch the alarm off early if you wish.



- Press the alarm off button.

The alarm will stop.

If the alarm is due to the temperature rising, the alarm symbol  will stay on until the correct temperature has been reached.

Storing food in the refrigerator section

Different storage zones

Due to the natural circulation of the air in the appliance, there are different temperature zones in the refrigerator. Cold, heavy air sinks to the lowest section of the appliance. Make use of the different zones when placing food in the appliance.

Warmest area

The warmest area is in the top section at the front and in the door. Use this for storing butter and cheese.

Coldest area

The coldest area in the refrigerator section is directly above the fruit and vegetables drawer (depending on model) or above the fruit and vegetable drawer (depending on model) and at the back of the appliance.

Use this for all delicate and highly perishable food, e.g.

- fish, meat, poultry,
- sausage products, ready meals,
- dishes or baked goods containing eggs or cream,
- fresh dough, cake mixtures, pizza or quiche dough,
- soft cheese and other dairy products,
- pre-packed vegetables and other fresh food with a label stating it should be kept at a temperature of approx. 4°C .

Do not store explosive materials in the appliance or any products containing propellants (e.g. spray cans).

Danger of explosion.

If storing alcohol with a high percentage proof, make sure it is tightly closed, and store upright.

If storing food which contains a lot of fat or oil in the refrigerator or refrigerator door, make sure that it does not come into contact with plastic components as this could cause stress cracks or break the plastic.

Food must not touch the back wall, as it may freeze to the back wall.

To allow air to circulate efficiently, do not pack food too closely together in the refrigerator. Do not cover the fan in the rear wall of the refrigerator, as this is essential for keeping the appliance cool.

Storing food in the refrigerator section

Food which is not suitable for storing in the refrigerator

Not all food is suitable for storing in a refrigerator at temperatures below 5°C as some food is sensitive to cold.

The appearance, consistency, taste and / or the vitamin content of certain types of food can be adversely affected by being stored in too cold a place.

Food which does not tolerate cold temperatures includes:

- Pineapples, avocados, bananas, pomegranates, mangos, melons, papayas, passion fruit, citrus fruit (such as lemons, oranges, mandarins, grapefruit),
- Fruit which is not yet ripe,
- Aubergines/egg plant, cucumber, potatoes, peppers/capiscum, tomatoes, courgettes/zucchini,
- Some hard cheeses, e.g. Parmesan.

When shopping for food

The freshness of food when first placed in the appliance is an important factor in determining how long it stays fresh, and how long it can be kept in the refrigerator.

Always observe the use-by date and recommended storage temperature. Time out of the refrigerator, e.g. during transportation, should be kept to a minimum. For example, do not allow food to stay in a hot car for too long.

Tip: Take a cool bag with you when shopping and on return place food into the appliance immediately.

Storing food in the refrigerator section

Storing food correctly

Food should generally be stored **covered or packaged**. This will prevent food smells from affecting other food, food from drying out, and also any cross-contamination of bacteria. This is particularly important for protein-based food such as meat or fish.

The growth of bacteria, such as salmonella, can be avoided by setting the correct temperature and maintaining good standards of hygiene.

Fruit and vegetables

Fruit and vegetables can be stored loose in the the fruit and vegetable containers or drawer (depending on model).

Protein rich food

Please note that food rich in protein deteriorates faster than others. Shellfish, for example, deteriorates faster than fish, and fish deteriorates faster than meat.

Adjusting the interior fittings

Adjusting the door shelf/bottle shelf

- Push the door/bottle shelf upwards, then remove it by pulling it forwards.
- Replace the door/bottle shelf at the required position. Ensure that it is pushed back into position securely.

Moving the bottle holder

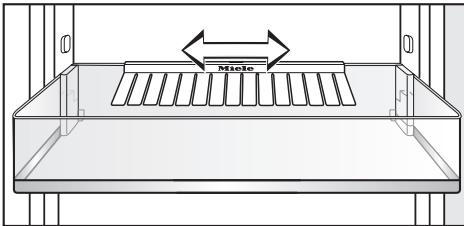

The bottle holder can be moved to the left or right to create more room for drinks cartons, for example.

The bottle holder can be removed completely (e.g. for cleaning).

- Push the bottle shelf upwards, then remove it by pulling it forwards.
- Pull the bottle holder upwards to remove it from the rear edge of the bottle shelf.

Moving the shelves

The shelves can be adjusted according to the height of the food.

- Raise the shelf slightly at the front, and pull it forwards a little until the notch at the side is in line with the shelf support. It can then be raised or lowered to the required level.

The raised edge of the protective strip at the back of the shelf must face upwards to prevent food from touching the back of the appliance and freezing to it.

Stoppers prevent the shelves from being dislodged by mistake.

Maximum freezing capacity

To ensure that fresh food placed in the freezer freezes through to the core as quickly as possible, the maximum freezing capacity must not be exceeded. The maximum freezing capacity for freezing within a 24-hour period is given on the data plate: "Freezing capacitykg/24 hrs".

The maximum freezing capacity given on the data plate has been calculated according to DIN EN ISO 15502 Standard.

Freezing fresh food

Fresh food should be frozen as quickly as possible. This way the nutritional value of the food, its vitamin content, appearance and taste are not impaired.

Food which takes a long time to freeze will lose more water from its cells, which then shrink.

During the defrosting process, only some of this water is reabsorbed by the cells; the rest collects around the food. In practice this means that the food loses a large degree of its moisture. You can tell if this has happened by the amount of liquid around the food.

If food is frozen quickly, the cells have less time to lose moisture, so they shrink less. As there is not so much moisture loss, it is easier for the food to reabsorb it during the defrosting process, and very little water collects around the defrosted food.

Storing frozen food

When buying frozen food to store in your freezer, check

- that the packaging is not damaged,
 - the use-by date,
 - the temperature at which the frozen food is being stored in the shop. The length of time it can be kept is reduced if it has been stored at a temperature warmer than -18 °C.
- Buy frozen food once you have finished the rest of your shopping, and wrap it in newspaper or use a cool bag or cool box to transport it.
 - Store it in the freezer as soon as possible.

Never re-freeze partially or fully defrosted food. Consume defrosted food as soon as possible as it will lose its nutritional value and spoil if left for too long. Defrosted food may only be re-frozen after it has been cooked.

Freezing and storing food

Home freezing

Only freeze fresh food which is in a good condition.

Hints on home freezing

- The following types of food **are suitable** for freezing:
Fresh meat, poultry, game, fish, vegetables, herbs, fresh fruit, dairy products, pastry, leftovers, egg yolks, egg whites and a range of pre-cooked meals.
- The following types of food **are not suitable** for freezing:
Grapes, lettuce, radishes, sour cream, mayonnaise, eggs in their shells, onions, whole raw apples and pears.
- To retain colour, taste and vitamin C, vegetables should be blanched after they have been trimmed and washed.
To blanch: bring a large saucepan of water to the boil, immerse the vegetables in the fast boiling water for 2-3 minutes, depending on variety. Remove, and plunge into ice-cold water to cool quickly. Drain and pack ready for freezing.
- Lean meat freezes better than fatty meat, and can be stored for considerably longer.
- To prevent chops, steaks, cutlets or rolled meat from freezing together in solid blocks when packed, separate with a sheet of plastic freezer film.

- Do not season fresh food or blanched vegetables before freezing. Only season cooked food lightly before freezing, but care should be taken as the taste of some spices alters when frozen.
- Do not place hot food or drinks in the freezer. This causes already frozen food to thaw, and increases the energy consumption considerably. Allow hot food and drinks to cool down before placing them in the freezer.

Packaging

- Freeze food in portions.

Unsuitable packaging material

- wrapping paper
- grease-proof paper
- cellophane
- bin bags
- plastic carrier bags

Suitable packaging material

- plastic freezer film
- freezer bags
- aluminium foil
- freezer containers
- Expel as much air as possible from bags etc. before sealing them, to prevent freezer-burn on food.
- Close the packaging tightly with
 - rubber bands
 - plastic clips
 - string or bag ties
 - freezer tape.

Freezer bags may also be sealed using home heat sealing kits.

Freezing and storing food

- Make a note of the contents and the date of freezing on the packaging.

Before placing food in the freezer section

- When freezing more than 1 kg of fresh food, switch on the Super freeze function for some time before placing the food in the freezer (see "Using Super freeze").

This helps food that is already in the freezer section to stay frozen.

Placing food in the freezer section

The following maximum capacities must be observed:

- freezer drawer = 25 kg
- glass cold plate = 35 kg

Food to be frozen must on no account touch food which is already frozen to avoid partial thawing.

- Make sure that the packaging and containers are dry to prevent them sticking together when frozen.

– Freezing small amounts of food

Place the food in the upper freezer drawers.

- Place the food flat in the bottom of the drawers so that it freezes through to the core as quickly as possible.

– Freezing the maximum amount (see data plate)

- Remove the upper freezer drawers.
- Place the food flat on the upper glass cold plates so that it freezes through to the core as quickly as possible.

Once frozen:

- Place the frozen food in the freezer drawers and push them back into the appliance.

– Large items

If you wish to freeze large items such as a turkey or game, the glass cold plates between the drawers can be removed.

- Remove the freezer drawers and carefully lift and slide out the glass cold plates.

Freezing and storing food

Defrosting

Frozen food can be defrosted in different ways:

- in a microwave oven,
- in an oven using the "Fan" or "Defrost" setting,
- at room temperature,
- in the refrigerator (the cold given off by the frozen food helps to keep the other food cold),
- in a steam oven.

Poultry It is particularly important to observe food hygiene rules when defrosting poultry. Do not use the liquid from defrosted poultry. Pour it away and wash the container it was in, the sink and your hands. Danger of salmonella poisoning.

Ensure that **meat and fish** (e.g mince, chicken, fish fillets) do not come into contact with other foods while defrosting. Catch the liquid and dispose of it carefully.

Fruit should be defrosted at room temperature in its packaging, or in a covered bowl.

Most vegetables can be cooked while still frozen. Just put straight into boiling water or hot fat. The cooking time is slightly less than that of fresh vegetables due to changes in the cell structure.

Never re-freeze partially or fully defrosted food. Consume defrosted food as soon as possible as it will lose its nutritional value and spoil if left for too long. Defrosted food may only be re-frozen after it has been cooked.

Ice cubes

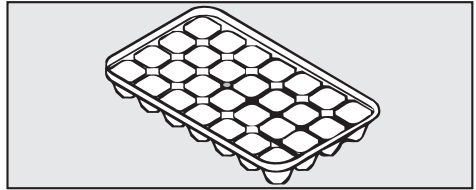

- Fill the ice tray three quarters full with water, and place it in the bottom of one of the drawers.
- Once frozen, use a blunt instrument, for example a spoon handle, to remove the ice tray from the freezer.
- Ice cubes can be removed easily from the tray by twisting the tray gently or by holding it under cold running water for a short while.

Cooling drinks

When cooling drinks quickly in the freezer, make sure bottles **are not** left in for more than one hour; otherwise they could burst.

Refrigerator section

The refrigerator section defrosts automatically.

Condensate and frost can build up on the back wall of the refrigerator section whilst it is in use. You do not need to remove this, as it will defrost and evaporate automatically with the warmth generated by the compressor.

The condensate is drained away via a channel and drain hole into an evaporation system at the back of the appliance.

Ensure that the condensate channel and drain hole are kept clean and are never blocked so that condensate can flow away without hindrance.

Freezer section

This appliance is equipped with a "Frost free" system. The freezer defrosts automatically.

The moisture generated in the appliance collects on the condenser and is automatically defrosted and dissipated by the condenser from time to time.

- This automatic defrosting system enables the freezer section to remain permanently ice-free, however, the food stored in the freezer section will not defrost.

Cleaning and care

Do not let water get into the electronic unit or into the light.

Do not let water get into the condensate channel and drain hole when cleaning.

Do not use steam cleaning apparatus to clean the appliance. Steam could reach electrical components and cause a short circuit.

The data plate located inside the appliance must not be removed. It contains information which is required in the event of a service call.

To avoid damaging the surfaces of your appliance, do not use:

- cleaning agents containing soda, ammonia, acids or chlorides,
- cleaning agents containing descaling agents,
- abrasive cleaning agents, e.g. powder cleaners and cream cleaners,
- solvent-based cleaning agents,
- stainless steel cleaning agents,
- dishwasher cleaner,
- oven sprays,
- glass cleaning agents,
- hard, abrasive sponges and brushes, e.g. pot scourers,
- melamine eraser blocks,

- sharp metal scrapers.

Before cleaning

- Switch the appliance off.
The display will go and the cooling system switches off.
If this does not happen the lock is active (see "Selecting settings - To deactivate the lock").
- Disconnect the appliance from the mains electricity supply.
- Take any food out of the appliance and store it in a cool place.
- Take out any removable parts, e.g. shelves, for cleaning.

Adjustable shelves

Before cleaning shelves remove the stainless steel trim from the front and the protective strip from the back of the shelf. To do this:

- Place the shelf on a worktop covered with a soft material (e.g. a tea towel).
- Pull the stainless steel trim off the shelf, beginning at one side.
- Pull the protective strip off the shelf.
- After cleaning the shelf reattach the stainless steel trim and protective strip.

Cleaning the interior and accessories

The appliance should be cleaned regularly, at least once a month.

Remove any obvious soiling immediately and do not let it dry on.

- Clean the interior surfaces and accessories with a solution of lukewarm water and a little washing-up liquid. After cleaning, wipe with clean water and dry with a soft cloth.

The following are **dishwasher safe**:

- the bottle holder, egg trays, ice cube tray (supplied as standard, depending on model)
- the shelves and bottle shelf in the door
- the adjustable shelves (excluding any stainless steel trim or protective strip)

The temperature of the dishwasher programme must not exceed 55 °C. Contact with some foodstuffs, such as carrots, tomatoes or ketchup can cause plastic items to discolour. However, this discolouration will not affect the stability of plastic items.

The following are **not dishwasher safe**:

- the stainless steel trim and the protective strips on the shelves and door shelves
- the fruit and vegetable drawer
- the freezer drawers
- These should all be hand washed.
- Clean the condensate channel and drain hole frequently, so that condensate can drain away unhindered. Use a straw or similar to clear the drain hole if necessary.
- Leave the doors open to air the appliance for a short while.

Ventilation gaps

- The ventilation gaps should be cleaned on a regular basis with a brush or vacuum cleaner. A build-up of dust will increase the energy consumption of the appliance.

Cleaning and care

Door seals

Do not use any oils or grease on the door seals as these will cause the seal to deteriorate and become porous over time.

- The door seals should be cleaned regularly with clean water, and then wiped dry with a soft cloth.

After cleaning

- Replace all shelves and accessories in the appliance.
- Reconnect to the mains and switch the appliance back on.
- Switch on the Super freeze function for a while so that the appliance can cool down quickly.
- Place food back in the refrigerator section and close the doors.
- Once the freezer section has reached the required temperature, place the food back in the freezer drawers and put them back in the freezer.

Problem solving guide

Some minor problems can be corrected without contacting Miele. The following overview is designed to help you resolve these yourself.

If having followed the suggestions below, you still cannot resolve the problem, please contact Miele.

To prevent unnecessary loss of temperature it is advisable not to open the appliance while waiting for it to be serviced.

Unauthorised installation, maintenance and repairs can cause considerable danger to users. Installation, maintenance and repair work must only be carried out by a Miele authorised technician.

Problem	Possible cause	Remedy
The appliance is not getting cold. The interior lighting does not come on when the door is opened and the display is not lit up.	The appliance has not been switched on.	■ Switch the appliance on. The display should then light up.
	The plug is not inserted in the socket correctly.	■ Insert the plug in the socket correctly and switch on. When the appliance is switched off the mains connection symbol  appears in the display.
	Check whether the mains fuse has tripped. There could be a fault with the appliance, the household electrical wiring or another electrical appliance.	■ Contact a qualified electrician or Miele.



Problem solving guide

The compressor is switching on too frequently and for too long, so the temperature in the appliance is dropping.		
Problem	Possible cause	Remedy
The temperature inside the appliance is too low.	The temperature inside the appliance is set too low.	■ Set the correct temperature setting.
	The freezer section door is not properly closed.	■ Close the door and make sure it closes properly.
	Has a large amount of fresh food been put in at the same time for freezing?	■ See "Freezing and storing food" for more information.
	The Super freeze function is still switched on. It will switch itself off automatically after approx. 65 hours.	You can switch off the Super freeze function earlier to save energy: ■ Press the Super freeze button.
The compressor runs all the time.	To save energy, the compressor runs at a lower speed when less cooling is required. The compressor will run for longer when this happens.	This is normal and does not require attention.

Problem solving guide

Problem	Possible cause	Remedy
<p>The compressor switches on too frequently and for longer.</p>	<p>The ventilation gaps in the housing unit are covered or dusty.</p>	<ul style="list-style-type: none"> ■ Uncover the ventilation gaps. ■ Dust the ventilation gaps regularly.
	<p>The refrigerator door or the freezer door has been opened too frequently, or a large amount of fresh food has been put in at once for storing or freezing.</p>	<ul style="list-style-type: none"> ■ Only open doors when you need to and then only for as long as necessary. <p>The appliance will regain the required temperature after a short while.</p>
	<p>The doors are not properly closed. There might be a thick layer of ice in the freezer section.</p>	<ul style="list-style-type: none"> ■ Close the doors. <p>The appliance will regain the required temperature after a short while.</p> <p>If a thick layer of ice has built up the cooling system will not work efficiently and energy consumption will increase.</p> <ul style="list-style-type: none"> ■ Defrost and then clean the appliance.
	<p>The ambient temperature is too high. The higher the ambient temperature, the longer the compressor will run for.</p>	<ul style="list-style-type: none"> ■ See "Installation - Location" for more information.
	<p>The appliance is not correctly installed in its housing unit.</p>	<ul style="list-style-type: none"> ■ See "Building in the appliance".

Problem solving guide

The compressor is switching on less frequently than it should and for shorter periods of time, so the temperature in the appliance is increasing.		
Problem	Possible cause	Remedy
The temperature inside the appliance is too high.	This is not a fault.	<ul style="list-style-type: none"> ■ Set the correct temperature settings. ■ Check the temperature again in 24 hours time.
Frozen food is starting to thaw.	<p>The room temperature is lower than the ambient temperature required for the appliance.</p> <p>Operating in a room which is too cold will cause the compressor to switch off for too long causing the freezer section to become too warm.</p>	<ul style="list-style-type: none"> ■ See "Installation - Location" for more information. ■ Raise the temperature in the room.
Messages in the display		
Problem	Possible cause	Remedy
<i>F0</i> to <i>F9</i> appear in the display.	There is a fault.	<ul style="list-style-type: none"> ■ Call Miele Service.
The Alarm symbol  flashes in the display together with the temperature display.	<p>The temperature inside the appliance is too warm because</p> <ul style="list-style-type: none"> – The door has been opened too frequently. – A large amount of fresh food has been put in at once for freezing without switching on the Super freeze function. – There has been a lengthy interruption to the power supply. 	<p>The Alarm symbol  will go out when the temperature reaches the correct level again.</p> <ul style="list-style-type: none"> ■ Depending on the temperature in the freezer section, you should check the condition of the food. If food has defrosted or started to defrost, check that it is still safe to use, and if so, use it as quickly as possible. Defrosted food may only be re-frozen after it has been cooked.

Problem solving guide

Interior lighting		
Problem	Possible cause	Remedy
The interior lighting is not working.	The appliance has not been switched on.	■ Press the On/Off button.
	To avoid overheating, the lighting switches itself off automatically after approx. 15 minutes if the door is left open. If this is not the case, then there is a fault.	Call Miele Service. The LED lighting may only be repaired or replaced by a Miele service technician. There are live electrical components under the cover. Danger of injury and damage to the appliance. Do not remove the lighting cover. If the cover is damaged or needs to be removed due to damage, exercise caution. There are lasers in the lighting (laser beam class 1M) which you should avoid looking at directly. Do not use optical instruments (magnifying glass or similar) to look at the lighting either.

Problem solving guide

Other problems		
Problem	Possible cause	Remedy
The freezer section door cannot be opened several times in succession.	This is not a fault. The suction caused by opening and closing the door several times in succession is preventing it from opening. Wait a few minutes and then try again. It should now open without force.	This is normal and does not require attention.
Food has frozen together.	The packaging used was not dry when put into the freezer section.	<ul style="list-style-type: none"> ■ Use a blunt instrument, e.g. a spoon handle or plastic scraper, to prise it apart carefully.
You cannot switch the appliance off.	The lock has been activated. The  symbol will appear in the display.	<ul style="list-style-type: none"> ■ Deactivate the lock (see "Selecting settings - To deactivate the lock").
The external side panels of the appliance feel warm.	This is not a fault. The warmth created by the evaporator is used to prevent condensation.	This is normal and does not require attention.
The floor of the refrigerator section is wet.	The condensate drain hole is blocked.	<ul style="list-style-type: none"> ■ Clean the condensate channel and drain hole.

Noises

Normal noises	What causes them
Brrrrr...	Humming noise made by the motor (compressor). This noise can get louder for brief periods when the motor is switching on.
Blubb, blubb....	A gurgling noise can be heard when coolant is circulating through the pipes.
Click....	Clicking sounds are made when the thermostat switches the motor on and off.
Sssrrrrr....	On multi-zone and frost-free appliances you can sometimes just hear the movement of air circulating inside the appliance.
	On appliances with a water container, the pump makes a humming noise when water is being drawn into the water container.
Creak ...	Creaking sounds can be heard when material inside the appliance expands.

Remember that the noise of the compressor and the coolant circulating in the system is unavoidable.

Noises that you can easily rectify	Possible cause	Remedy
Rattling, vibrating	The appliance is uneven.	Realign the appliance using a spirit level, by raising or lowering the screw feet underneath the appliance.
	The appliance is touching another appliance or piece of furniture.	Move it away.
	Drawers, baskets or shelves are unstable or sticking.	Check all removable items and refit them correctly.
	Are any bottles or containers unstable or knocking against each other?	Separate them.
	The transport cable clips are hanging loose at the back of the appliance.	Remove the clips.

After Sales / Guarantee

In the event of a fault which you cannot correct yourself, or if the appliance is under guarantee, please contact:

– your Miele Dealer

or

– Miele (see back cover for contact details).

Please note that telephone calls may be monitored and recorded for training purposes.

When contacting your Dealer or Miele, please quote the model and serial number of your appliance. This information is given on the data plate inside the appliance.

N.B. A call-out charge will be applied for service visits where the problem could have been resolved as described in these instructions.

Guarantee

For information on the appliance guarantee specific to your country please contact Miele. See back cover for contact details.

In the U.K. your appliance is guaranteed for 2 years from the date of purchase. However, you must activate your cover by calling 0845 365 6640 or registering online at www.miele.co.uk.

Testing must be carried out in accordance with the **relevant Norms and Directives**.

In addition, the following manufacturer's instructions should be observed when preparing and carrying out tests:

- **Loading plans,**
- Instructions in the **Operating and installation instructions.**

Electrical connection

Electrical connection U.K.

All electrical work should be carried out by a suitably qualified and competent person in strict accordance with current local and national safety regulations (BS 7671 in the UK).

The appliance is supplied with a mains cable and moulded plug ready for connection to an a.c. single phase 220-240 V 50 Hz supply.

Please ensure that the connection data quoted on the data plate match the household mains supply.

Connection should be made via a suitable switched socket which is easily accessible. It must not be located behind the appliance. For extra safety it is advisable to protect the appliance with a suitable residual current device (RCD).

Do not connect the appliance to the mains electricity supply by an extension lead. Extension leads do not guarantee the required safety of the appliance (e.g. danger of overheating).

This appliance must not be connected to the inverter of an autonomous power supply, e.g. a solar power system. When switching the appliance on, a surge in power could trigger the safety cut-out mechanism. This could damage the electronic unit.

The appliance must not be used with so-called energy saving devices. These reduce the energy supply to the appliance which could then become too warm. Using such devices could alter the specification of the product.

If the connection cable has to be replaced, this must be done by a suitably qualified and competent person.

Do not plug other appliances in behind this appliance

Non-rewireable plugs (BS 1363)

The fuse cover must be re-fitted when changing the fuse, and if the fuse cover is lost, the plug must not be used until a suitable replacement is obtained. The colour of the correct replacement cover is that of the coloured insert in the base of the plug, or the colour that is embossed in words in the base of the plug (as applicable to the design of the plug fitted).

Replacement fuses should be ASTA approved to BS 1362 and have the correct rating. Replacement fuses and fuse covers may be purchased from your local electrical supplier.

WARNING
THIS APPLIANCE MUST BE
EARTHED

This appliance must be built in, otherwise it could tip up.

Location

This appliance should not be installed where it is exposed to direct sunlight or directly adjacent to a heat-producing appliance such as an oven or a radiator. The higher the ambient temperature of the room, the more energy the appliance requires to operate. The appliance should be installed in a dry well ventilated room.

When installing the appliance please be aware:

- The socket must be easily accessible in an emergency, not concealed behind the appliance.
- The plug and cable must not touch the rear of the appliance as they could be damaged by vibrations from the appliance.
- Do not plug in other appliances behind this appliance.

Important. In environments with high humidity condensation can build up on the exterior of the appliance. This can cause corrosion of the appliance walls. For prevention, it is advisable to install the appliance with sufficient ventilation in a dry and /or air-conditioned room. Make sure that the appliance door(s) closes properly, the ventilation gaps are not covered and the appliance is installed in accordance with these installation instructions.

Climate range

The appliance is designed for use within certain climate ranges (ambient temperatures) and should not be used outside this range. The climate range of the appliance is stated on the data plate inside the appliance.

Climate range	Ambient room temperature
SN	+10 °C to +32 °C
N	+16 °C to +32 °C
ST	+16 °C to +38 °C
T	+16 °C to +43 °C

Operating in a room which is too cold will cause the compressor to switch off for too long, causing the internal temperature in the appliance to rise with the risk of food deteriorating and going off.

Installation

Ventilation

Specified ventilation gaps must be maintained. Otherwise the compressor will come on more frequently and for longer, resulting in an increase in electricity consumption and also an increase in the operating temperature of the compressor, which can damage it.

Air at the back of the appliance gets warm. The appliance housing unit must be constructed to allow sufficient space for ventilation.

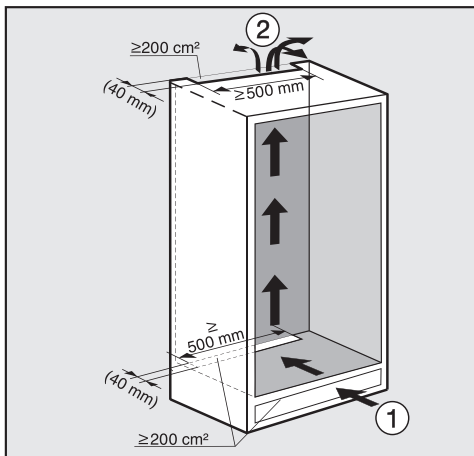

- Air is taken in through the plinth ① and exits upwards at the back of the housing unit ②.
- A ventilation gap of at least 40 mm depth must be provided behind the appliance for air to pass through.

- The cross-sectional area for ventilation in the plinth and the housing unit and also beneath the ceiling needs to be at least 200 cm² throughout to ensure that warm air can be drawn through unhindered.
- Important. The appliance uses less energy the larger the ventilation cross-section.

The ventilation gaps must not be covered or blocked in any way. They should be dusted on a regular basis.

Top ventilation gap

The ventilation gap at the top of the appliance can be constructed in different ways:

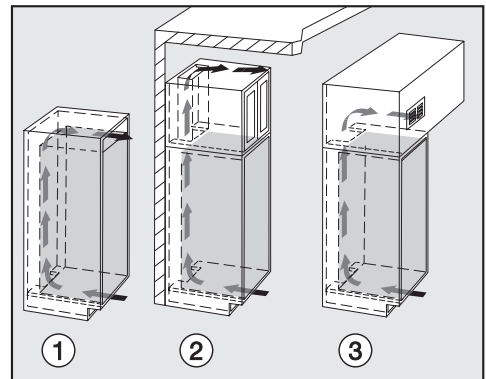

- ① directly above the appliance with a ventilation grille (free airflow of at least 200 cm²)
- ② in between the housing unit and the ceiling
- ③ through a suspended ceiling

Before installing the appliance

- Take the accessory pack which includes installation parts and other accessories out of the appliance and remove the packaging strap holding the door in place.
- **Do not** remove the following from the back of the appliance:

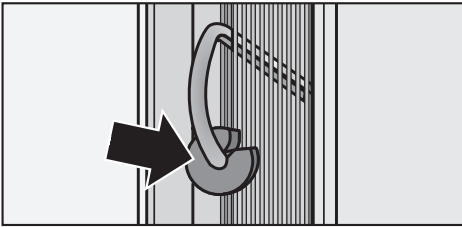

- The spacers (depending on model). These ensure the gap required between the back of the appliance and the wall is maintained.
- Depending on model, the pouches located in the metal grille (heat exchanger). They are required for the correct functioning of the appliance. The contents are not poisonous or dangerous.
- Remove any cable clips from the back of the appliance.
- Check that all parts at the back of the appliance are unhindered. Carefully remove any hindrance.

Building-in dimensions

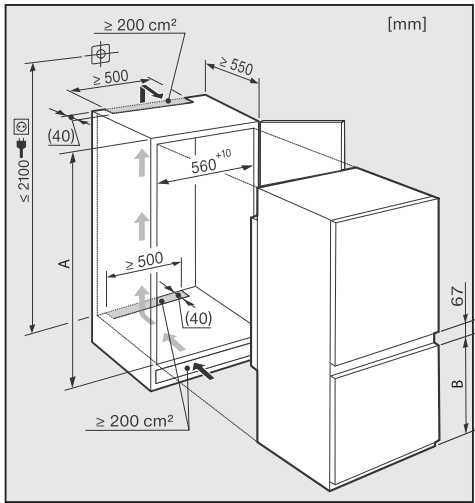

Before installing the appliance make sure the housing unit is the correct size. Specified ventilation gaps must be maintained in order to ensure that the appliance functions correctly.

	Niche height [mm]
	A
KDN 37132 iD	1772 – 1788

Changing the door hinging

Two people are needed for changing the door hinging.

The appliance is supplied right-hand hinged. If left-hand door hinging is required, follow the instructions below.

To change the door hinging you will need the following tools:

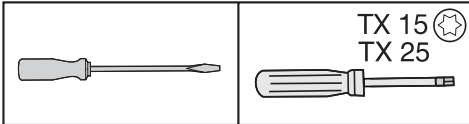

- Open both appliance doors.

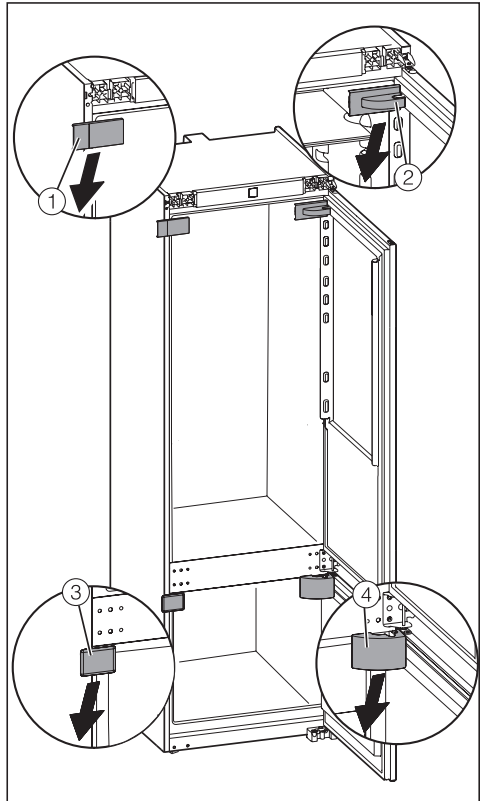

- Remove covers ①, ②, ③ and ④.

Changing the door hinging

Take care. The door is not secure once the screw has been taken out of the bearing block.

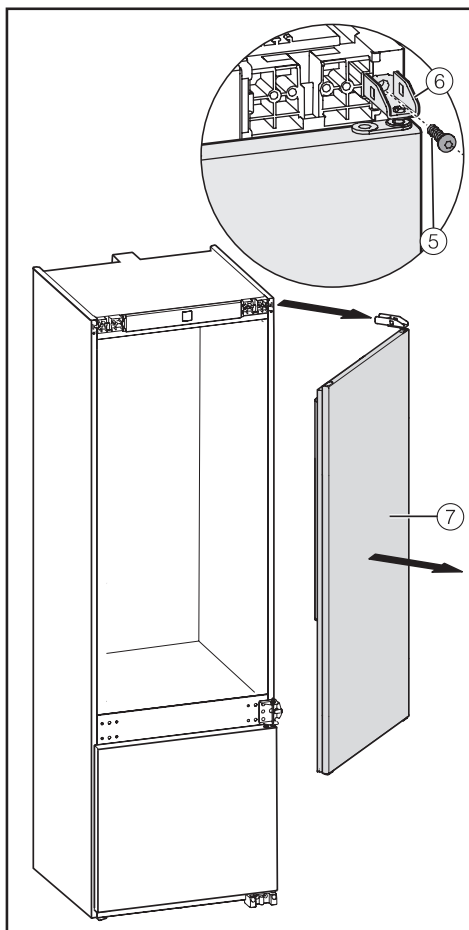

- Loosen screw ⑤ in bearing block ⑥.
- Push the door outwards ⑦, lift it off and place it to one side.

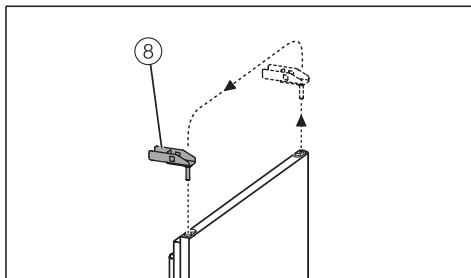

- Pull upper bearing block ⑧ out, and replace it on the opposite side.

Take care. The door is not secure as soon as the middle hinge pin has been removed.

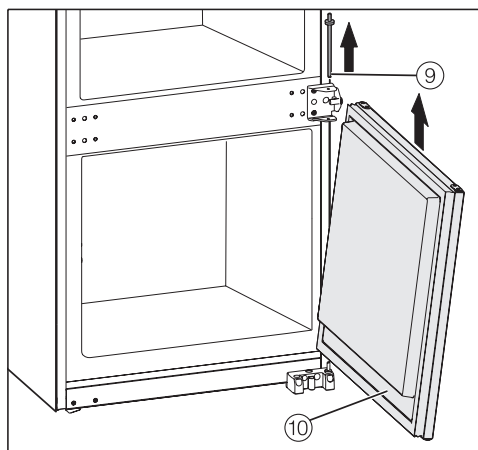

- Pull the middle hinge pin ⑨ upwards together with the washer to remove it.
- Carefully lift door ⑩ off and place it to one side.

Changing the door hinging

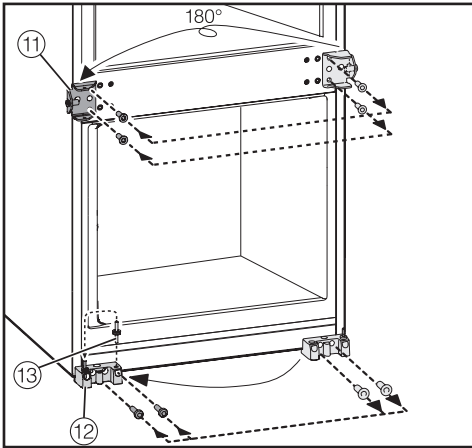

- Unscrew bearing block ⑪, turn it around and fit it on the opposite side.
- Unscrew bearing block ⑫, and screw it back in on the opposite side.
- Remove hinge pin ⑬ together with its washer and replace these on the opposite side.

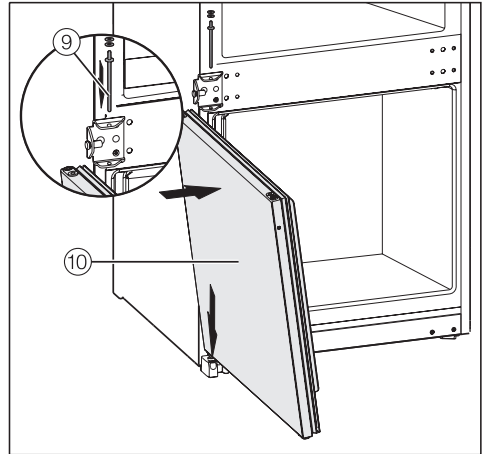

- Place the door onto hinge pin ⑩ from above.
- Close the lower door.
- In the middle of the appliance, fit hinge pin ⑨ with its washer through the bearing block in the appliance door ⑩ .

Changing the door hinging

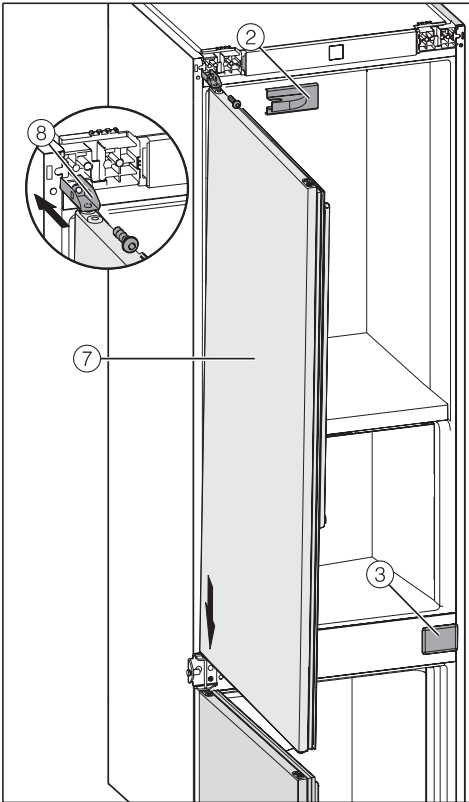

- Then fit upper door ⑦ onto the middle hinge pin.
- Close the upper door.
- Screw upper bearing block ⑧ back on the appliance securely.
- Tighten all screws again.
- Replace covers ② and ③.

Building in the appliance

Two people are needed for installing this appliance.

- The appliance must be installed in stable and correctly aligned kitchen furniture on a level surface.
- The housing unit must be secured against the risk of tipping.

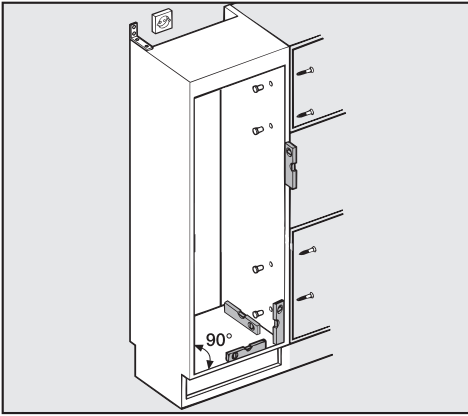

- Use a spirit level to align the housing unit.
The unit corners must be at right angles, as otherwise the furniture door will not align correctly with the 4 corners of the unit.
- The required ventilation gaps must be provided (see "Installation - Ventilation gaps").

To install the appliance you will need the following tools:

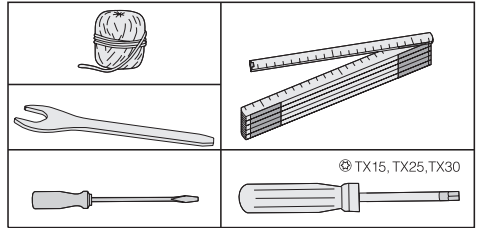

Building in the appliance

The following installation parts are required

All installation parts are number coded. This coding is also used in the installation instructions.

– required for installing the appliance in its housing unit:

① 1x	③ 1x		
④ 1x	⑥ 1x	⑦ 1x	
⑨ 1x	⑩ 1x	⑪ 2x	
⑬ 2x	⑭ 1x	⑮ 2x	
3,9 x 30V		3,9 x 37V	
⑰ 1x	⑱ 2x		
		⑳ 1x	

– required for fitting the furniture door:

⑳ 4x	㉑ 4x
㉓ 4x	㉔ 12x

All fitting instructions given are for a **right-hand hinged** appliance. If you have converted the appliance to left-hand hinging you will need to adapt these instructions accordingly.

■ Position the appliance in front of the housing unit.

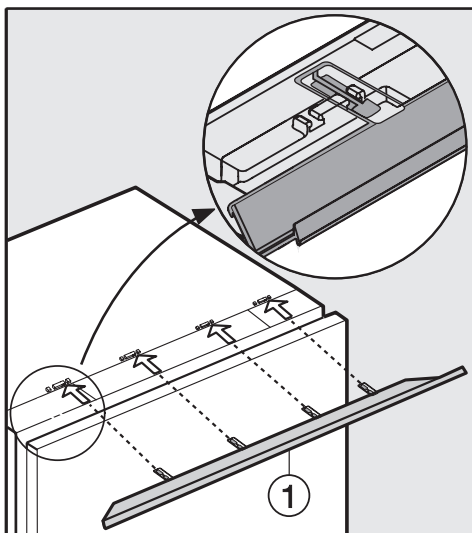

■ Fit cover strip ① into position.

Building in the appliance

- Push the appliance two-thirds of the way into its niche.
When doing this, make sure that the mains cable does not get trapped.

Tip to help you push it into position:

Secure a length of string to the plug to "increase" the length of the connection cable.

Then pull the cable by the end of the string through the housing unit. It will then be easier to connect once the appliance is in the unit.

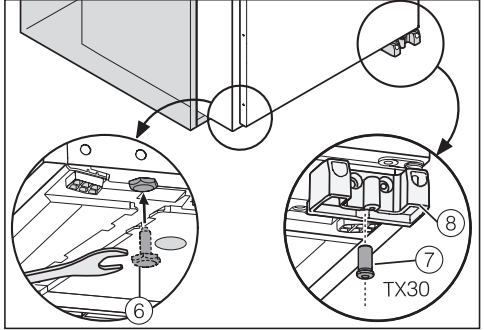

- Screw in adjustable foot ⑥ completely.
- Screw the second adjustable foot ⑦ right into bearing block ⑧.

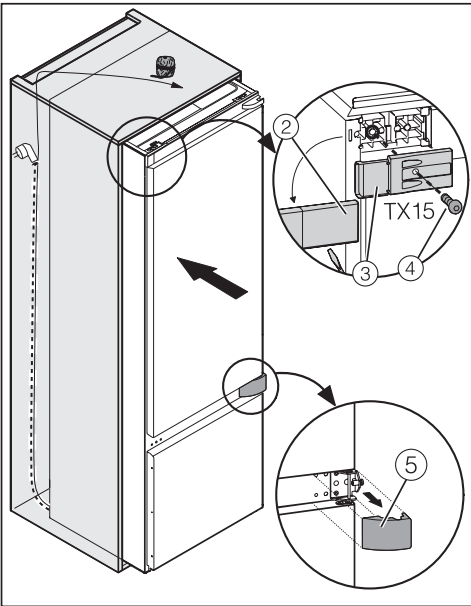

- Remove cover ② from the top corner of the appliance.
- Secure part ③ using screws ④ loosely into the top left-hand side of the appliance.
- Remove cover ⑤.

Building in the appliance

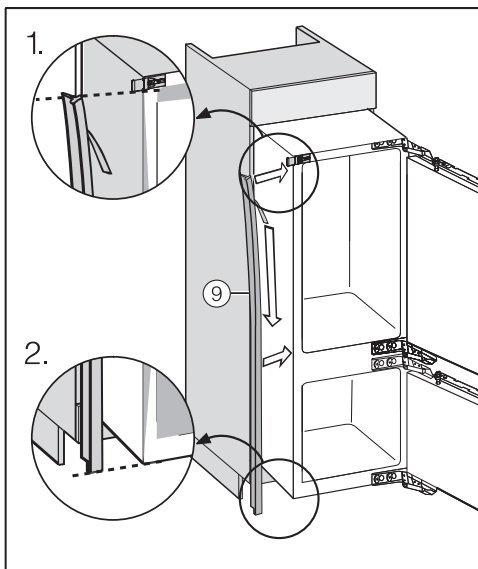

- Carefully remove the protective foil from sealing strip ⑨.
- Fix sealing strip ⑨ flush with the front of the appliance on the door opening side.
 1. Position the sealing strip flush with the lower edge of the top fixing.
 2. Stick it down along its entire length.

Installing the appliance

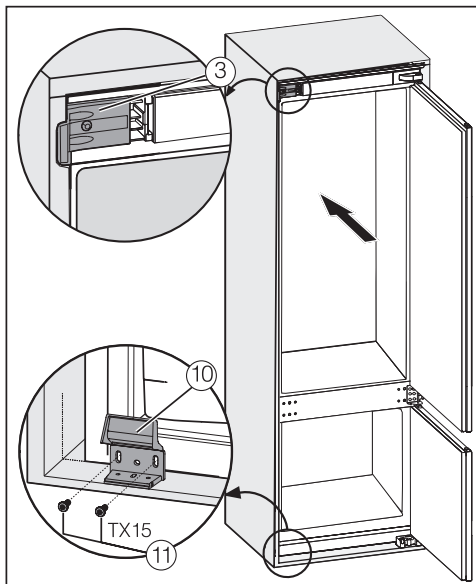

- Screw the lower fixing bracket ⑩ using screws ⑪ loosely into the bottom of the appliance.
- Push the appliance into the niche:
 - until the top fixing bracket ③ touches the front edge of the furniture side wall.
 - until the front edge of lower left-hand fixing bracket ⑩ and the lower right-hand fixing bracket is flush with the front edge of housing unit base.

A gap of 42 mm (from the appliance carcass to the front edge of the furniture side walls) must be maintained.

Building in the appliance

If the all round gap of 42 mm is not maintained between the appliance casing and the front edge of the housing unit side walls the door may **not** shut properly.

This can cause ice to build up, condensate to accumulate and lead to faults in the appliance. These can all lead to increased energy consumption.

On furniture with door fittings (e.g. stubs, seals etc) the dimension of these must be taken into account to ensure there is a gap all round of **42 mm**.

- Pull the appliance forwards by the dimension of the door fitting to keep the gap at 42 mm all round.

Tip: Remove the door fittings. This will ensure that the door is flush with the surrounding kitchen unit furniture doors.

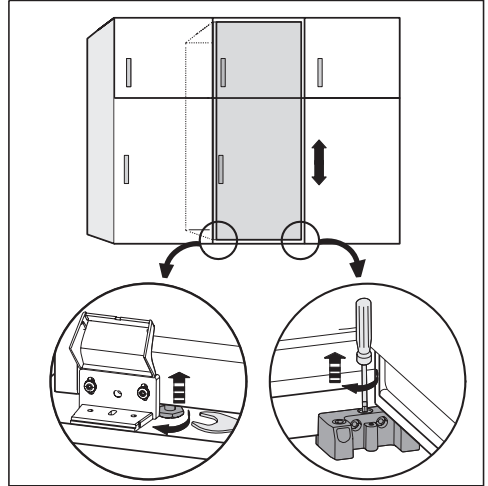

- Align the appliance on both side using the adjustable feet.

Building in the appliance

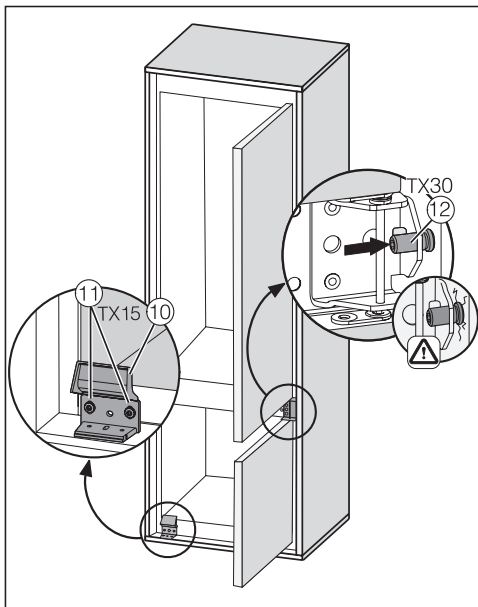

- Carefully unscrew adjusting screw ⑫ in the middle hinge plate until it touches the side wall of the furniture housing unit.
- Tighten screws ⑪ in fixing bracket ⑩.

Securing the appliance in the niche

Before securing the appliance in its niche make sure that both lower fixing brackets are flush with the front of the unit base.

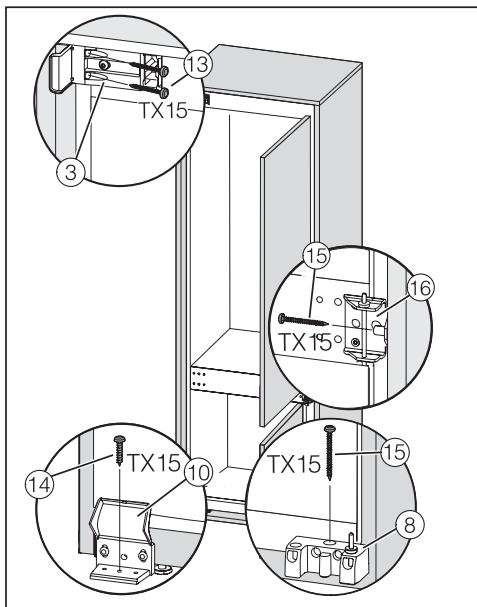

- Press the appliance up against the furniture wall and then secure the appliance with screws ⑬ through fixing bracket ③.
- Press the appliance up against the furniture wall and then secure fixing bracket ⑩ using screw ⑭ to the unit base.
- Secure the appliance by fitting screw ⑮ into bearing block ⑧.
- Finally secure the appliance at the side by fitting screw ⑮ through the middle bearing block ⑮.

Tighten all the screws.

Building in the appliance

For additional stability of the appliance in the unit, push the rods supplied underneath the appliance between it and the floor of the housing unit.

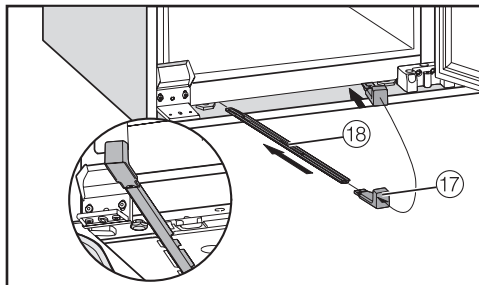

- Then secure handle ⑰ to one of the rods ⑱.
- Use the handle to push the rod into the guide as far as it will go. Remove the handle and fit it to the other rod and push this into its guide as far as it will go.

Important. Keep the handle somewhere safe in case you ever need to fit the appliance into a new housing unit.

- Close the appliance doors.

- If necessary, align the cover strip by pushing it parallel to the top of the unit - it should be set slightly back and must not protrude.

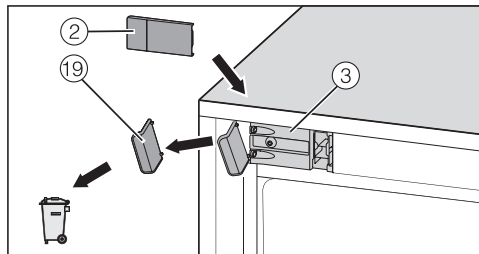

- Snap off any protruding end ⑲ on the top fixing bracket ③. It is no longer required.
- Refit cover ②.

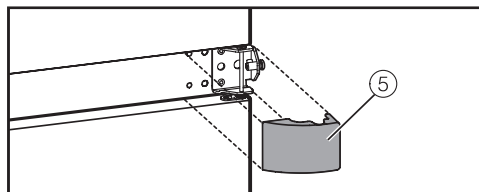

- Refit cover ⑤.

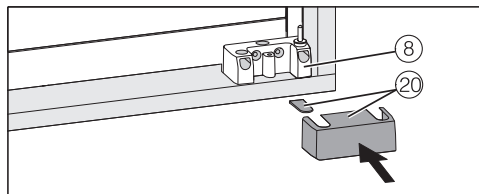

- Push the plastic tab into the left-hand aperture in cover ⑳, and then fit the cover in position.

Building in the appliance

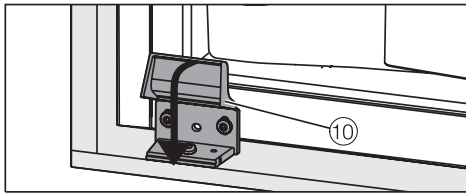

- Flip the cover on fixing bracket ⑩ down.

Securing the furniture door to the appliance door

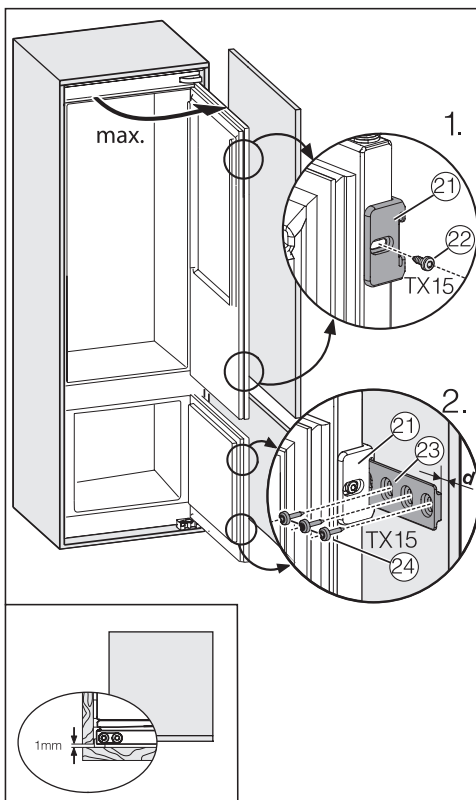

- Secure door fixing ⑳ to the appliance doors using screws ㉒.
- Open the door fully and push fixing guides ㉓ into door fixing ㉑.

- Position the furniture door onto the appliance door, and secure fixing guides ㉓ to the furniture door using screws ㉔. Maintain a distance d (= the thickness of the housing unit walls) between the edge of the appliance door and outer edge of the furniture door.
- Align the door fixing so that the furniture door on the side with the handle does not lie against the housing unit wall when the door is shut. A **minimum distance of 1 mm** must be maintained. This is vital for the longterm effectiveness of the insulation and ventilation.
- Tighten all screws again.

United Kingdom

Miele Co. Ltd.
Fairacres, Marcham Road
Abingdon, Oxon, OX14 1TW
Tel: 0845 365 0555, Fax: 0845 365 0777
Customer Contact Centre Tel: 0845 365 6600
E-mail: info@miele.co.uk
Internet: www.miele.co.uk

Australia

Miele Australia Pty. Ltd.
ABN 96 005 635 398
1 Gilbert Park Drive, Knoxfield, VIC 3180
Tel: 1300 464 353, Fax: (03) 9764 7149
Internet: www.miele.com.au

China

Miele (Shanghai) Trading Ltd.
1-3 Floor, No. 82 Shi Men Yi Road
Jing' an District
200040 Shanghai, PRC
Tel: +86 21 6157 3500, Fax: +86 21 6157 3511
E-mail: mieleshanghai@cn.miele.com
Internet: www.miele.cn

Miele (Hong Kong) Limited

41/F - 4101, Manhattan Place
23 Wang Tai Road
Kowloon Bay
Hong Kong
Tel: (852) 2610 1331, Fax: (852) 2610 1013
Email: mielehk@miele.com.hk

India

Miele India Pvt. Ltd.
Ground Floor, Copia Corporate Suites
Plot No. 9, Jasola
New Delhi – 110025
Tel: 011-46 900 000, Fax: 011-46 900 001
E-mail: customercare@miele.in, Internet: www.miele.in

Ireland

Miele Ireland Ltd.
2024 Bianconi Avenue
Citywest Business Campus, Dublin 24
Tel: (01) 461 07 10, Fax: (01) 461 07 97
E-Mail: info@miele.ie, Internet: www.miele.ie

Manufacturer: Miele & Cie. KG

Carl-Miele-Straße 29, 33332 Gütersloh, Germany

Miele

Malaysia

Miele Sdn Bhd
Suite 12-2, Level 12
Menara SapuraKencana Petroleum
Solaris Dutamas No. 1, Jalan Dutamas 1
50480 Kuala Lumpur, Malaysia
Phone: +603-6209-0288
Fax: +603-6205-3768

New Zealand

Miele New Zealand Limited
Unit L, 10-20 Sylvia Park Road
Mt. Wellington, 1060, Auckland, NZ
Tel: 0800 264 353, Fax: 0800 463 453
Internet: www.miele.co.nz

Singapore

Miele Southeast Asia
Miele Pte. Ltd.
163 Penang Road
04 - 02/03 Winsland House II
Singapore 238463
Tel: +65 6735 1191, Fax: +65 6735 1161
E-Mail: infosea@miele.com.sg
Internet: www.miele.sg

South Africa

Miele (Pty) Ltd
63 Peter Place, Bryanston 2194
P.O. Box 69434, Bryanston 2021
Tel: (011) 875 9000, Fax: (011) 875 9035
E-mail: info@miele.co.za
Internet: www.miele.co.za

United Arab Emirates

Miele Appliances Ltd.
P.O. Box 11 47 82
Gold & Diamond Park
Sheikh Zayed Road
Building 6 / Offices Nos. 6-214 to 6-220
Dubai
Tel: +971-4-341 84 44
Fax: +971-4-341 88 52
E-Mail: info@miele.ae, Internet: www.miele.ae